

[Home](#) / [BMW E70 X5 xDrive35i SAV](#) / [Repair Manuals and Technical Data](#) / [34 Brakes](#) / [34 00 Braking, check, ventilation](#) / [34 00 050](#) **Bleeding brake system with DSC**



**E72For: Warning!**  
High-voltage system - danger to life!



**E72For: Warning!**  
Compliance with the following points is mandatory before beginning work:

- Observe [safety instructions](#) for handling hybrid cars



**Necessary preliminary work:**

- [Remove left microfilter housing cover](#)
- [Read and comply with General Information.](#)



**Important!**

When replacing or repairing, observe the filling and bleeding instructions for the following parts:

- Tandem brake master cylinder
- Hydraulic unit
- Components and connecting lines which are fitted between these assemblies.
- For E72: SBA control unit

Connect bleeder unit with max. 2 bar filling pressure.

A second person is needed to help carry out this work.

Use only BMW-approved brake fluids, see [BMW operating fluids](#).

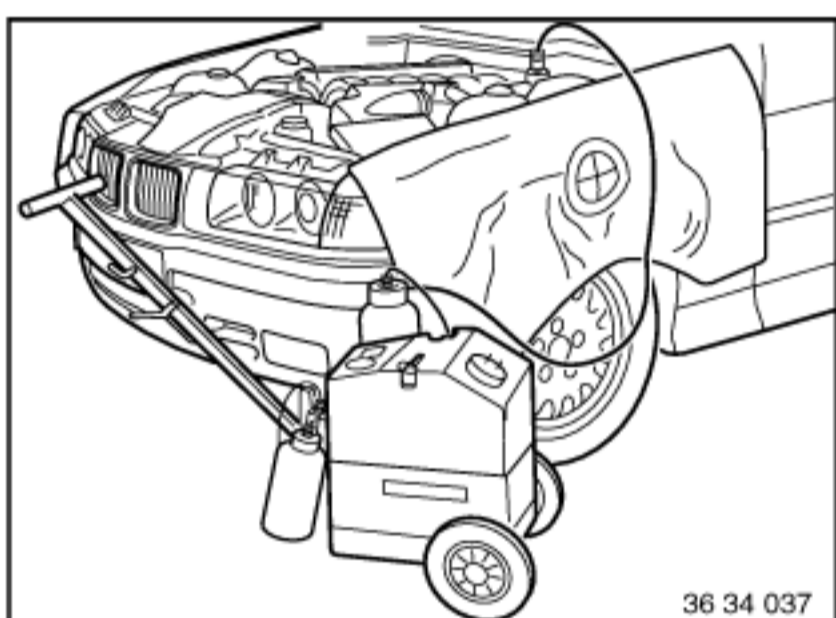

Connect DIS.

Select path: Service functions - Chassis/Suspension - Traction control systems - Bleeding procedure.

**Important!**

Check relevant equipment manufacturer's operating instructions for each device.

Charging pressure should not exceed 2 bar.

Connect brake fluid changer to expansion tank and switch on.

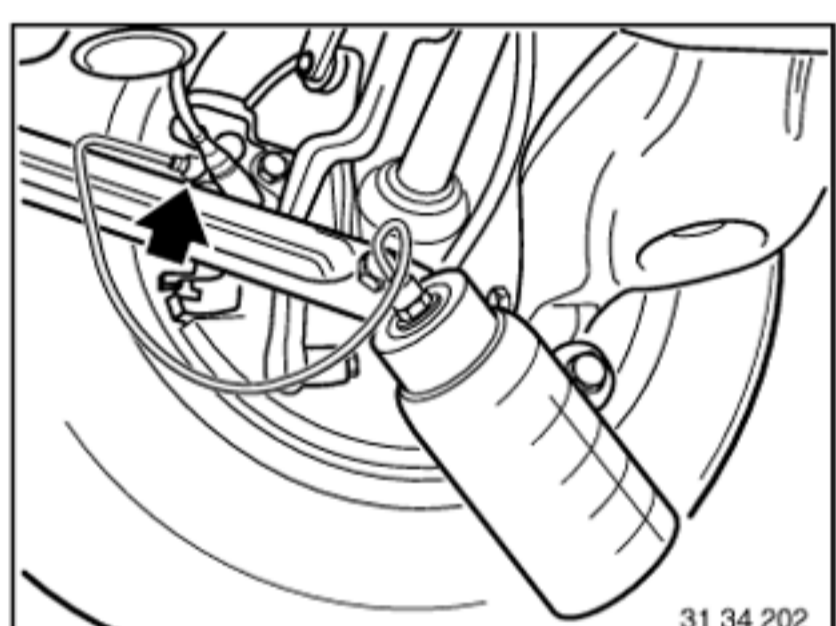

**Fully rinse the brake system**

Connect vent hose with collecting vessel to vent valve on rear right brake caliper.

Open vent valve and purge until clear, bubble-free brake fluid emerges.

Close vent valve.

Follow same procedure on rear left, front right and front left wheel brake.

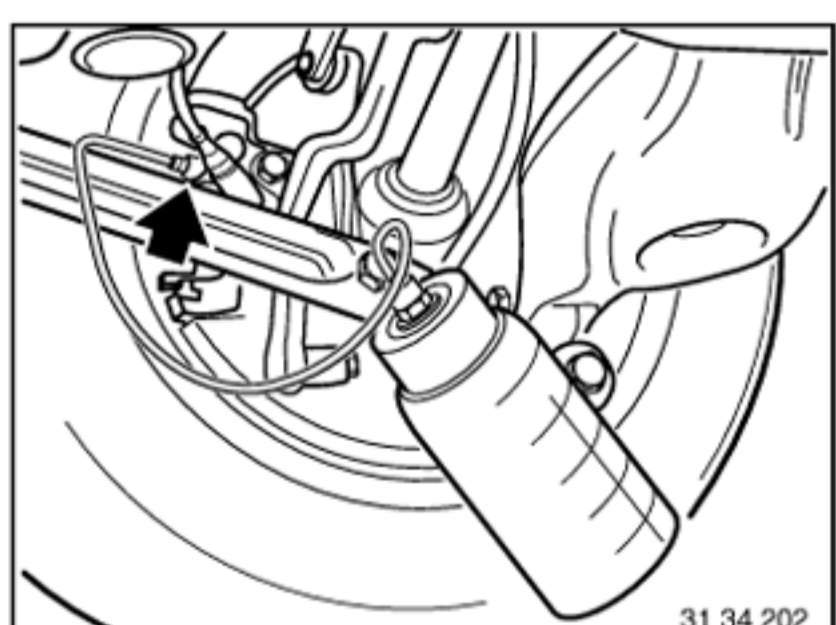

**Bleeding rear axle brake circuit**

Connect vent hose with collecting vessel to vent valve on rear right brake caliper.

Close vent valve.

Run brake bleeding procedure with DIS with vent valve open.

After completing routine, press brake pedal 5 times to floor; clear and bubble-free brake fluid must flow out.

Close vent valve.

Repeat procedure at rear left.

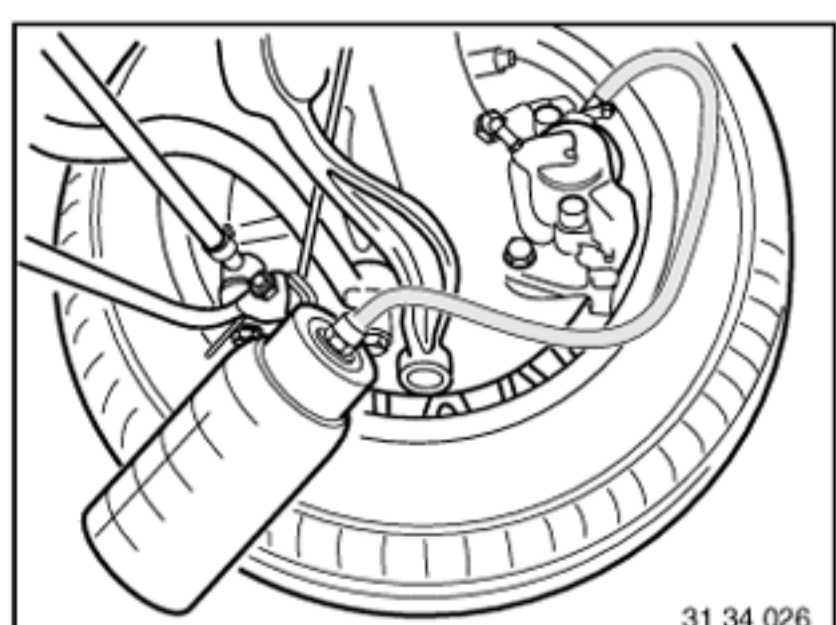

**Bleeding front axle brake circuit**

Connect vent hose with collecting vessel to vent valve on front right brake caliper.

Close vent valve.

Run brake bleeding procedure with DIS with vent valve open.

After completing routine, press brake pedal 5 times to floor, clear and bubble-free brake fluid must flow out.

Close vent valve.

Repeat procedure at front left.

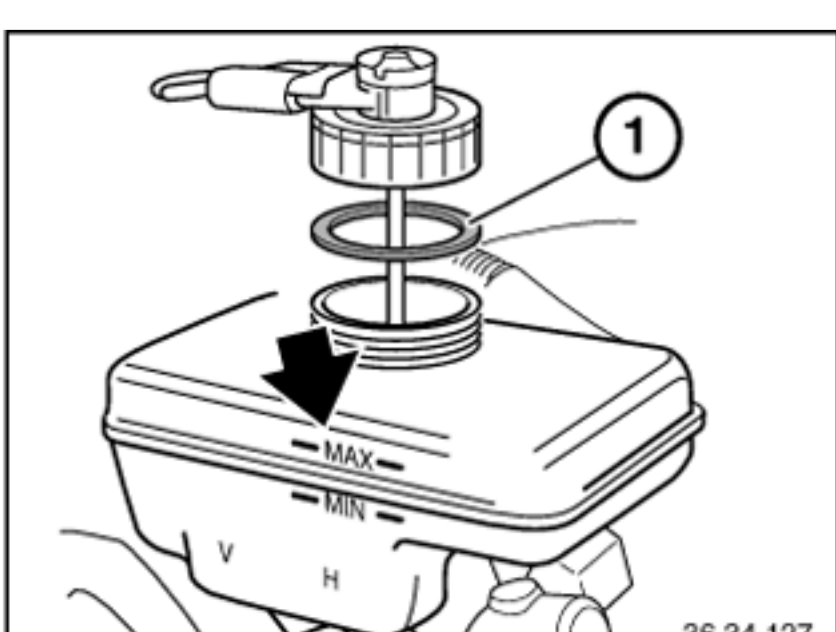

Switch off brake fluid changer and remove from expansion tank.

Check brake fluid level. If necessary, top up/draw off to max. level.

Close expansion tank.

**Note:**

Pay attention to rubber seal (1) in sealing cap.